



Checks to be carried out on receipt of the actuator

1. If the actuator arrives already assembled onto the valve, the setting of the mechanical stops and of the electric limit switches (if existing) has already been made by the person who assembled the actuator onto the valve. If the actuator arrives separately from the valve, the setting of the mechanical stops and of the electric limit switches (if existing) must be checked and, if necessary, carried out while assembling the actuator onto the valve.
2. Check that the actuator has not been damaged during transport. If necessary, repair all damages to the paint-coat, etc.
3. Check that the model, the serial number of the actuator and the performance data written on the data-plate are in accordance with those described on the order acknowledgement, test certificate and delivery note.
4. Check that the fitted accessories comply with those listed in the order acknowledgement and the delivery note.

Storage

The actuators leave the factory in excellent working conditions and with an excellent finish (these conditions are guaranteed by an individual inspection certificate); in order to maintain these characteristics until the actuator is installed on the plant, it is necessary to observe a few rules and take appropriate measures during the storage period.

1. Make sure that plugs are fitted in the air connections and in the cable entries. The plastic plugs which close the inlets do not have a weatherproof function, but are only a means of protection against the entry of foreign matter during transport. If long-term storage is necessary and especially if the storage is outdoor, the plastic protection plugs must be replaced by metal plugs, which guarantee a complete weatherproof protection.
2. If the actuators are supplied separately from the valves, they must be placed onto a wooden pallet so as not to damage the coupling flange to the valve. In case of long-term storage, the coupling parts (flange, drive sleeve, insert bush) must be coated with protective oil or grease. If possible, blank off the flange by a protection disk.

3. In case of long-term storage, it is advisable to keep the actuators in a dry place or to provide at least some means of weather protection. If possible, it is also advisable to periodically operate the actuator with filtered, dehydrated and lubricated air; after such operations all the threaded connections of the actuator and the valves of the control panel (if present) should be carefully plugged.

Assembling the actuator onto the valve

The actuator can be assembled onto the valve flange either by using the actuator housing flange with threaded holes, or by the interposition of an adaptor flange or a spool piece. The actuator drive sleeve is generally connected to the valve stem by an insert bush or a stem extension. The assembly position of the actuator, with reference to the valve, must comply with the plant requirements (cylinder axis parallel or perpendicular to the pipeline axis). To assemble the actuator onto the valve proceed as follows:

1. check that the coupling dimensions of the valve flange and stem, or of the relevant extension, meet the actuator coupling dimensions
2. bring the valve to the "Closed" position
3. lubricate the valve stem with oil or grease in order to make the assembly easier. Be careful not to pour any of it onto the flange
4. clean the valve flange and remove anything that might prevent a perfect adherence to the actuator flange and especially all traces of grease, since the torque is transmitted by friction
5. if an insert bush or stem extension for the connection to the valve stem is supplied separately, assemble it onto the valve stem and fasten it by tightening the proper stop dowels
6. bring the actuator to the "Closed" position
7. connect a sling to the support points of the actuator and lift it: make sure the sling is suitable for the actuator weight. When possible, it is easier to assemble the actuator to the valve if the valve stem is in the vertical position. In this case the actuator must be lifted while keeping the flange in the horizontal position
8. clean the actuator flange and remove anything that might prevent a perfect adherence to the valve flange and especially all traces of grease
9. lower the actuator onto the valve in

such a way that the insert bush, assembled on the valve stem, enters the actuator drive sleeve. This coupling must take place without forcing and only with the weight of the actuator. When the insert bush has entered the actuator drive sleeve, check the holes of the valve flange. If they do not meet with the holes of the actuator flange or the stud bolts screwed into them, the actuator drive sleeve must be rotated; feed the actuator cylinder with air at the proper pressure or actuate the manual override, if existing, until coupling is possible

10. tighten the nuts of the connecting stud bolts evenly with the torque prescribed in the table. The stud bolts must be made of ASTM A320 L 7 steel, the nuts must be made of ASTM A194 grade 2 steel

Thread size	Recommended tightening torque (Nm)
M 8	20
M10	40
M12	70
M14	110
M16	160
M20	320
M22	420
M24	550
M27	800
M30	1100
M33	1400
M36	1700

11. if possible, operate the actuator to check that it moves the valve smoothly.

Setting of the angular stroke

It is important that the mechanical stops of the actuator (and not those of the valve) stop the angular stroke at both extreme valve positions (fully open and fully closed), except when this is required by the valve operation (e.g. metal seated butterfly valves).

The setting of the open valve position is performed by adjusting the travel stop screw in the left wall of the mechanism housing, or in the end flange of the manual override, if existing.

The setting of the closed valve position is performed by adjusting the travel stop screw in the cylinder end flange. Proceed as follows:

- loosen the lock nut
- if the actuator angular stroke is stopped before reaching the end position (fully open or closed), unscrew the stop screw by turning it

anticlockwise, until the valve reaches the correct position. When unscrewing the stop screw, keep the lock nut still with a wrench so that the sealing washer does not withdraw together with the screw

- tighten the lock nut
- If the actuator angular stroke is stopped beyond the end position (fully open or closed), screw the stop screw by turning it clockwise until the valve reaches the correct position
- tighten the lock nut.

Preparation for start-up

1. Pneumatic connections

Connect the actuator to the pneumatic feed line with fittings and pipes in accordance to the plant specifications. They must be sized correctly in order to guarantee the necessary air flow for the operation of the actuator, with pressure drops not exceeding the maximum allowable value. The shape of the connecting piping must not cause excessive stress to the inlets of the actuator. The piping must be suitably fastened so as not to cause excessive stress or loosening of threaded connections, if the system undergoes strong vibrations.

Every precaution must be taken to ensure that any solid or liquid contaminants which may be present in the pneumatic pipework to the actuator are removed to avoid possible damages to the unit or loss of performance. The inside of the pipes used for the connections must be well cleaned before use: wash them with suitable substances and blow through them with air or nitrogen. The ends of the tubes must be well deburred and cleaned.

Once the connections are completed, operate the actuator and check that it functions correctly, that the operation times meet the plant requirements and that there are no leaks in the pneumatic connections.

2. Electrical connections

Connect the electrical feed, control and signal lines to the actuator, by linking them up with the terminal blocks of the electrical components. In order to do this, the housing covers must be removed without damaging the coupling surfaces, the O-rings or the gaskets. Remove the plugs from the cable entries. For electrical connections use components (cable glands, cables, hoses, conduits) which meet the requirements and codes applicable to the plant specifications (mechanical

protection and/or explosionproof protection). Screw the cable glands tightly into the threaded inlets, so as to guarantee the weatherproof and explosionproof protection (when applicable). Insert the connection cables into the electrical enclosures through the cable glands, and connect the cable wires to the terminals according to the applicable wiring diagram. If conduits are used, it is advisable to carry out the connection to the electrical enclosures by inserting hoses so as not to cause anomalous stress on the housing cable entries. Replace the plastic plugs of the unused enclosure entries by metal ones, to guarantee perfect weatherproof tightness and to comply with the explosionproof protection codes (where applicable).

Once the connections are completed, check that the controls and signals work properly.

Start-up

During the start-up of the actuator, proceed as follows:

- check that the pressure and quality of the air supply (filtering degree, dehydration) are as prescribed. Check that the feed voltage values of the electrical components (solenoid valve coils, microswitches, pressure switches, etc.) are as prescribed
- check that the actuator controls work properly (remote control, local control, emergency controls, etc.)
- check that the required remote signals (valve position, air pressure, etc.) are correct
- check that the setting of the components of the actuator control unit (pressure regulators, pressure switches, flow control valves, etc.) meet the plant requirements
- check that there are no leaks in the pneumatic connections. If necessary tighten the nuts of the pipe fittings
- remove all rust and, in accordance with the applicable painting specifications, repair paint-coat that has been damaged during transport, storage or assembly.

Maintenance

Important: before carrying out any maintenance operation, it is necessary to close the pneumatic feed line and exhaust the pressure from the actuator cylinder and from the control unit, to ensure the safety of maintenance staff.

a. Routine maintenance

ALGA actuators have been designed to

work for long periods in the severest conditions with no need for maintenance. It is, however, advisable to periodically check the actuator as follows:

- check that the actuator operates the valve correctly and with the required operating times. If the actuator operation is very infrequent, carry out a few opening and closing operations with all the existing controls (remote, local, emergency controls, etc.), if this is allowed by the plant conditions
- check that the signals to the remote control desk are correct
- check that the air supply pressure value is within the required range
- if there is an air filter on the actuator, bleed the condensed water accumulated in the cup by opening the drain cock. Disassemble the cup periodically and wash it with soap and water; disassemble the filter: if this is made of a sintered cartridge, wash it with nitrate solvent and blow through it with air. If the filter is made of cellulose, it must be replaced when clogged
- check that the external components of the actuator are in good conditions
- check all the paint-coat of the actuator. If some areas are damaged, repair the paint-coat according to the applicable specification
- check that there are no leaks in the pneumatic connections. If necessary tighten the nuts of the pipe fittings.

b. Special maintenance

If there are air leaks in the pneumatic cylinder or a malfunction in the mechanical components, or in case of scheduled preventative maintenance, the actuator must be disassembled and seals must be replaced with reference to the sectional drawing (page 4) and adopting the following procedures:

b1. Replacement of cylinder seals (see sectional drawing)

Disassembly:

- remove the nuts (16) and the washers (24) from the tie rod (18) at the end flange (22) side
- slide off the end flange (22) and the tube (19)
- remove the screws (2) and the cover (1)
- unscrew the piston rod (20) threaded end from the adaptor bush (30) of guide block (14)
- slide off the piston rod (20) from the head flange (17)
- disassemble the head flange (17) from the mechanism housing (8) by removing the screws (15) only if the gasket (36) has to be replaced because damaged.

Seals replacement

Prior to reassembly check that the actuator components are in good condition and clean. Lubricate all the surfaces of the parts which move in contact with other components by a recommended grease (see paragraph b2). If the O-ring must be replaced, remove the existing one from its groove, clean the groove carefully and lubricate it with a protective oil or grease film. Assemble the new O-ring into its groove and lubricate it with a protective oil or grease film.

- Replace the O-rings (39 and 40) of the head flange (17).
- Replace the O-ring (42) and the guide sliding ring (41) of the piston.
- Replace the O-ring (40) of the end flange (22).

If the sealing washer (43) has to be replaced, measure the protrusion of the stop screw (26) with reference to the end flange (22) surface, so as to be able to easily restore the setting of the actuator mechanical stop in the closed valve position, once the maintenance procedures have been completed.

- Loosen the lock nut (25) and unscrew the stop screw (26) until it is removed together with the nut (25), the washer (44) and the sealing washer (43).
- Remove the sealing washer (43) from the stop screw (26). Carefully clean and lubricate the stop screw thread and the surface of the end flange area, on which the sealing washer is.
- Screw the new sealing washer onto the stop screw until it touches the nut (25).
- Assemble the washer (44) onto the sealing washer (43).
- Screw the stop screw into the threaded hole of the end flange until it reaches its original position (the same protrusion with reference to the flange surface).
- Check that the sealing washer (43) and the washer (44) are in contact with the flange surface.
- Tighten the lock nut (25).

Reassembly:

- assemble the new gasket (36) after cleaning the surfaces of housing (8) and head flange (17), which are in contact
- assemble the head flange (17), replace the washers (37) if damaged, tighten the screws (15) to the recommended torque (see table)
- lubricate the piston rod (20) surface with a protective oil or grease film and introduce it into the head flange hole, taking care not to damage the O-ring (39). Carefully clean the threaded end of piston rod (20) and the threaded hole of the adaptor bush (30) of the guide block (14). Spread some sealant LOCTITE 542, or equivalent, on the rod threaded end and screw it into the adaptor bush (30) threaded hole, then tighten
- carefully clean the inside of the tube (19) and check that the entire surface, particularly that of the bevels, is not damaged. Lubricate with a protective oil or grease film the tube internal surface and the bevels. Slide the tube onto the piston taking care not to damage the piston O-ring (42) and the head flange O-ring (40)
- assemble the end flange by centering it on the inside diameter of the tube, taking care not to damage the O-ring (40)
- assemble the washers (24) and the nuts (16) onto the tie rods (18). Tighten the nuts to the recommended torque (see table), alternating between opposite corners
- restore a generous coating of grease on the contact surfaces of the yoke (11) and the bushings (33), on the yoke grooves, on the sliding blocks (5), on the guide bar (9)
- assemble the new gasket (10) after cleaning the surfaces of the housing (8) and cover (1)
- lubricate the O-ring (32) with protective oil or grease
- assemble the cover (1) and the screws (2). Tighten the screws to the recommended torque
- carry out a few actuator operations to check that movement is regular and that there are no air leaks through the seals.

b2. Lubrication of mechanism

For normal duty the scotch yoke mechanism of the actuator is lubricated "for life". In case of high load and high frequency of operation it may be necessary to periodically restore lubrication: it is advisable to apply a generous coating of grease on the contact surfaces of the yoke and bushings, on the yoke link grooves, on the sliding blocks, on the guide bar. For this operation it is necessary to disassemble the mechanism cover. In large actuators the lubrication can be performed through the inspection holes of the cover after removing the plugs.

The following grease is used by BIFFI for standard working temperature and suggested for relubrication:

Manufacturer	: AGIP
Type	: GR MU/EPI
NLGI grade	: 1
Worked penetration (dmm)	: 325
Drop point ASTM (°C)	: 185
ISO grade	: X1
Equivalent greases:	
	ESSO BEACON EP1
	BP LTX 1
	SHELL ALVANIA GREASE R1

For special working conditions and for working temperatures beyond the standard range consult BIFFI.

After maintenance operations carry out a few actuator operations to check that movement is regular and that there are no air leaks through the seals.

ALGA Pneumatic Actuator

instruction and operating manual

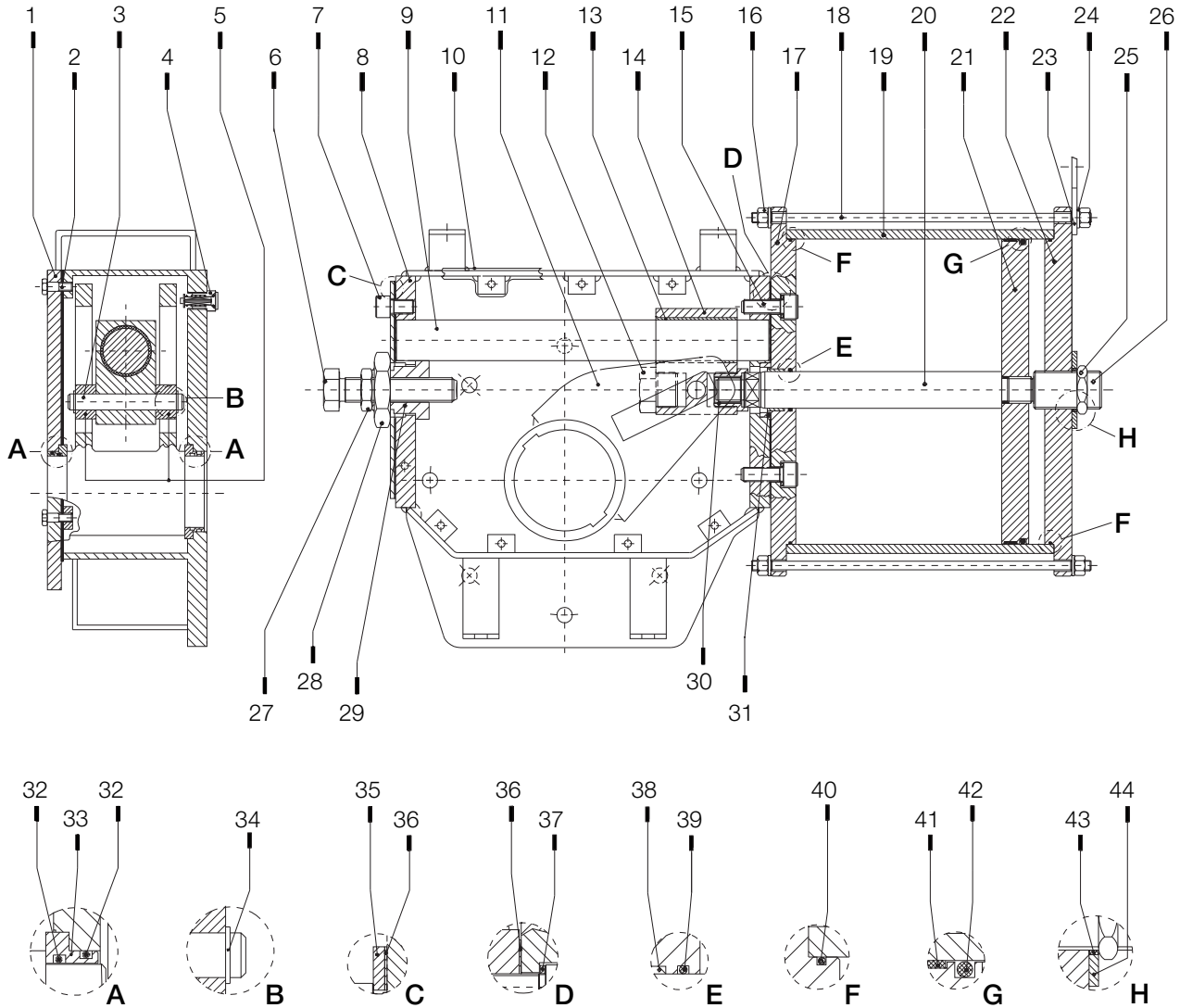

ALGA pneumatic actuator

Item	Name	Item	Name	Item	Name
1.	Cover	16.	Nut	31.	Washer
2.	Screw	17.	Head flange	32.	O-ring
3.	Guide block pin	18.	Tie rod	33.	Yoke bushing
4.	Vent valve	19.	Cylinder tube	34.	Retainer ring
5.	Sliding block	20.	Piston rod	35.	Flange
6.	Travel stop screw	21.	Piston	36.	Gasket
7.	Screw	22.	End flange	37.	Washer
8.	Housing	23.	Lifting eyelet	38.	Piston rod bushing
9.	Guide bar	24.	Spring washer	39.	O-ring
10.	Cover gasket	25.	Nut	40.	O-ring
11.	Yoke	26.	Travel stop screw	41.	Piston guide sliding ring
12.	Plug	27.	Nut	42.	O-ring
13.	Bushing	28.	Nut	43.	Sealing washer
14.	Guide block	29.	Stop screw bush	44.	Washer
15.	Screw	30.	Adaptor bush		

ALGA-IME

A.C./Grafiche Malvezzi/1.500/01.98